

REVISIONS			
CHG. NO.	LTR.	DESCRIPTION	DATE APPD.

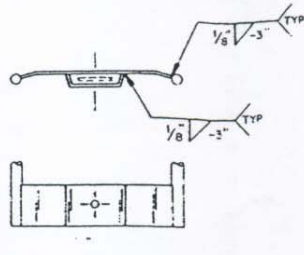

TYP. CABLE BRKT.

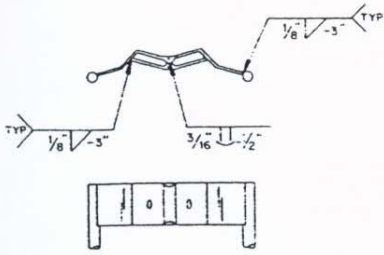

TYP. SHEAVE BRKT.

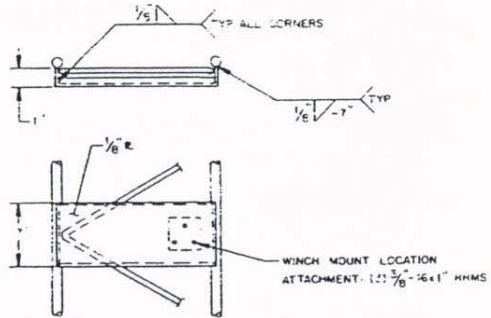

WINCH MTG. PLATE

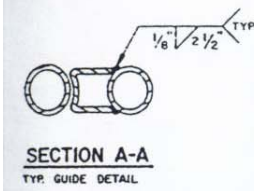

SECTION A-A  
TYP. GUIDE DETAIL

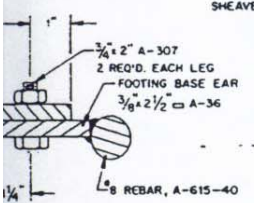

SECTION B-B

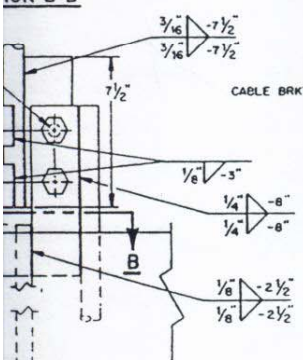

SECTION DETAIL

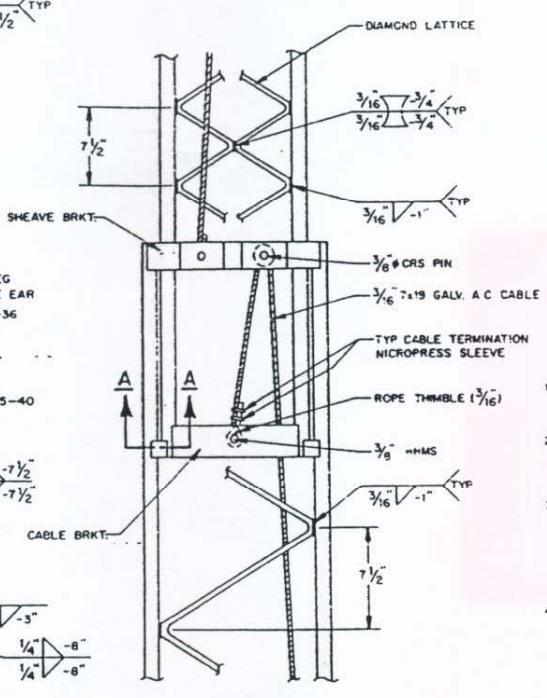

TYP. SECTION LAP

ITEM	APPLICATION	MAT'L. DESCRIPTION	SPECIFICATIONS	NOTES
LEG TUBES	SECTION 3	1" O65" WALL	A-500	45 KSI MIN. YIELD
	SECTION 4	1" O95" WALL		
	SECTION 5	1.25" x .20" WALL		
LATTICE	SECTION 3 & 4 SECTION 5	5/16 DIA 3/8" DIA	A-36	
RAISING SYSTEM BRACKETS	SECTION 3, 4 & 5	1/8" x 3"	A-570-36	
RAISING CABLES		7x19 GALV. A.C. CABLE	4,200 lb. MIN. CERT. BREAKING STR.	
RAISING WINCH		DL 1500 CR EQUIV.	1,500 lb. RATED LOAD	AUTO-FRICT. BRAKE
FOOTING REINFORCEMENT	FOOTING	SEE DRAWING DETAIL	A-615-40	

NOTES:

- GENERAL - A. TOWER DESIGNED IN ACCORDANCE WITH UBC.  
B. TOWER MANUFACTURED BY TELEX/HY-GAIN.
- MATERIALS - ALL MATERIALS SHALL BE STRUCTURAL GRADE STEEL, CERTIFIED FOR CONFORMANCE TO THE SPECIFICATIONS AND REQUIREMENTS AS LISTED IN THE MATERIALS TABLE AND AS NOTED IN THE DETAIL NOTES OF THIS DRAWING.
- WELDING - ALL TOWER WELDS SHALL BE IN ACCORDANCE WITH THE AWS D1.1 & D12.1 WELDING CODES AND SHALL BE PERFORMED BY WELDERS CERTIFIED IN ACCORDANCE WITH THE PROVISIONS AND REQUIREMENTS OF THE AWS. ELECTRODE SPECIFICATIONS ARE:  
A. TOWER STRUCTURE WELDS - E70-S3 OR EQUIVALENT.  
B. FOOTING REINFORCEMENT STRUCTURE WELDS - E7018 OR EQUIVALENT.
- FOUNDATION - FOUNDATION CONSISTS OF SINGLE REINFORCED CONCRETE FOOTING. THE DESIGN HEREIN SPECIFIED IS FOR SOILS WITH A MINIMUM 200 PSF/FT LATERAL BEARING PRESSURE. INSTALLATIONS IN SOILS OF LESSER CAPACITY, OR LOOSE OR SOFT CHARACTERISTICS WILL REQUIRE ALTERNATE DESIGNS SPECIFIC FOR THE SITE CONDITIONS.  
A. CONCRETE QUANTITY - 2.73 YD<sup>3</sup>  
B. MIX LESS THAN 7.5 GAL. OF WATER PER SACK. MINIMUM 5.5 SACKS PER YD<sup>3</sup>.  
C. STRENGTH - 2,000 PSI, MINIMUM 28 DAYS.  
FOOTING STEEL REINFORCEMENT SHALL BE AS SPECIFIED IN THE FOOTING DETAIL AND SHALL BE POSITIONED AS SHOWN IN THE DETAIL. EARTH EXCAVATION FOR THE FOOTING SHALL BE ACCOMPLISHED SO AS TO LEAVE SOILS IMMEDIATELY ADJACENT TO THE FOOTING UNDISTURBED.
- FINISH - THE TOWER SHALL BE HOT DIP GALVANIZED PER ASTM A-123 AFTER FABRICATION.

3000 P/W  
HG-5255 (125-1) 871094

QTY.	DESCRIPTION	ITEM	PART NO.	SPECIFICATION
	TOLERANCES UNLESS OTHERWISE SPECIFIED	DATE	24 MARCH 83	<b>TELEX hy-gain</b> <small>TELEX COMMUNICATIONS, INC.            1500 BIRNEY U.S.A.</small> TITLE PRODUCT 125-1, TOWER INSTALLATION & SPECIFICATIONS FOR UBC
	FRACTION	DR BY	BEK	
	DECIMAL	CHK BY	END 8/12/83	
	ANGLE	APPD.	7/15 7-8-83	
		PROD.	HP 4-8-83	
NEXT ASSY.	USED ON	MATL.	CONTRACT	SIZE <b>D</b>
APPLICATION				CODE IDENT <b>57010</b>
				DWG. NO. <b>125-1</b>
				SCALE SHEET

This drawing, all or in part, is a proprietary product of TELEX, Chicago, Illinois, and shall not be copied, reproduced, or otherwise disseminated without the written permission of TELEX.

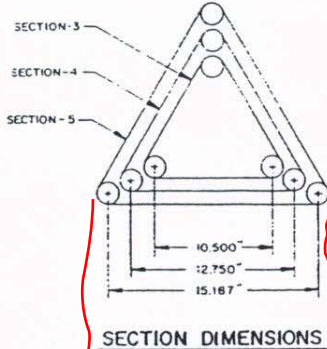
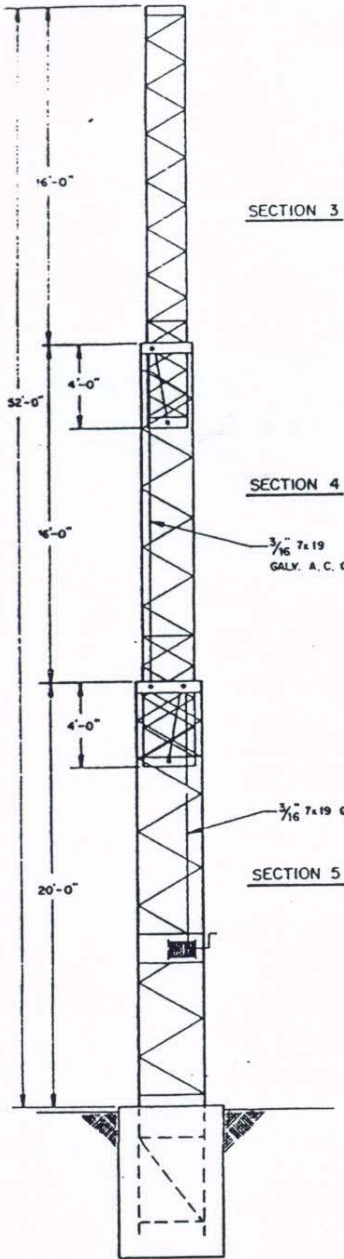

16.437

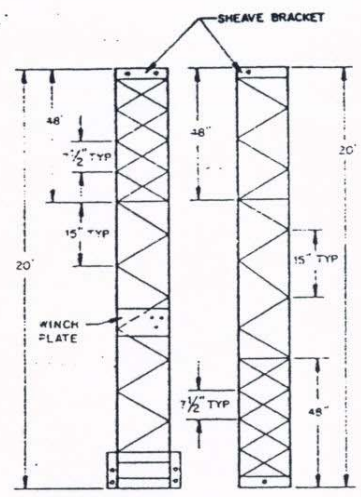

SECT. 5 SECT. 3 & 4  
BRACE CONFIGURATION

